

# SCIENCE



## FORMULA CHART

Density = $\frac{\text{mass}}{\text{volume}}$	$D = \frac{m}{v}$
$\left( \begin{array}{c} \text{heat gained} \\ \text{or lost} \end{array} \right) = \left( \begin{array}{c} \text{mass in} \\ \text{grams} \end{array} \right) \left( \begin{array}{c} \text{change in} \\ \text{temperature} \end{array} \right) \left( \begin{array}{c} \text{specific} \\ \text{heat} \end{array} \right)$	$Q = (m)(\Delta T)(C_p)$
Speed = $\frac{\text{distance traveled}}{\text{time}}$	$v = \frac{d}{t}$
Acceleration = $\frac{\text{final velocity} - \text{initial velocity}}{\text{change in time}}$	$a = \frac{v_f - v_i}{\Delta t}$
Momentum = mass $\times$ velocity	$p = mv$
Force = mass $\times$ acceleration	$F = ma$
Work = force $\times$ distance	$W = Fd$
Power = $\frac{\text{work}}{\text{time}}$	$P = \frac{W}{t}$
% efficiency = $\frac{\text{work output}}{\text{work input}} \times 100$	$\% = \frac{W_o}{W_i} \times 100$
Kinetic energy = $\frac{1}{2} (\text{mass} \times \text{velocity}^2)$	$KE = \frac{mv^2}{2}$
Gravitational potential energy = mass $\times$ acceleration due to gravity $\times$ height	$PE = mgh$
Energy = mass $\times$ (speed of light) <sup>2</sup>	$E = mc^2$
Velocity of a wave = frequency $\times$ wavelength	$v = f\lambda$
Current = $\frac{\text{voltage}}{\text{resistance}}$	$I = \frac{V}{R}$
Electrical power = voltage $\times$ current	$P = VI$
Electrical energy = power $\times$ time	$E = Pt$

<b>Constants/Conversions</b>		
$g = \text{acceleration due to gravity} = 9.8 \text{ m/s}^2$		
$c = \text{speed of light} = 3 \times 10^8 \text{ m/s}$		
speed of sound = 343 m/s at sea level and 20°C		
$1 \text{ cm}^3 = 1 \text{ mL}$		
1 wave cycle/second = 1 hertz (Hz)		
1 calorie (cal) = 4.18 joules		
1000 calories (cal) = 1 Calorie (Cal) = 1 kilocalorie (kcal)		
newton (N) = $\text{kgm/s}^2$		
joule (J) = Nm		
watt (W) = J/s = Nm/s		
volt (V)	ampere (A)	ohm ( $\Omega$ )

# Periodic Table of the Elements

Atomic number	14
Symbol	<b>Si</b>
Atomic mass	28.086
	Silicon

Group	1	2											13	14	15	16	17	18	
	IA	IIA											IIIA	IVA	VA	VIA	VIIA	VIIIA	
1	<b>H</b> 1.008 Hydrogen																		<b>He</b> 4.0026 Helium
2	<b>Li</b> 6.941 Lithium	<b>Be</b> 9.012 Beryllium																	<b>Ne</b> 20.179 Neon
3	<b>Na</b> 22.990 Sodium	<b>Mg</b> 24.305 Magnesium																	<b>Ar</b> 39.948 Argon
4	<b>K</b> 39.098 Potassium	<b>Ca</b> 40.08 Calcium	<b>Sc</b> 44.956 Scandium	<b>Ti</b> 47.88 Titanium	<b>V</b> 50.942 Vanadium	<b>Cr</b> 51.996 Chromium	<b>Mn</b> 54.938 Manganese	<b>Fe</b> 55.847 Iron	<b>Ni</b> 58.69 Nickel	<b>Cu</b> 63.546 Copper	<b>Zn</b> 65.39 Zinc	<b>Ga</b> 69.72 Gallium	<b>Ge</b> 72.61 Germanium	<b>As</b> 74.922 Arsenic	<b>Se</b> 78.96 Selenium	<b>Br</b> 79.904 Bromine	<b>Kr</b> 83.80 Krypton	<b>Xe</b> 131.29 Xenon	
5	<b>Rb</b> 85.468 Rubidium	<b>Sr</b> 87.62 Strontium	<b>Y</b> 88.906 Yttrium	<b>Zr</b> 91.224 Zirconium	<b>Nb</b> 92.906 Niobium	<b>Mo</b> 95.94 Molybdenum	<b>Tc</b> (98) Technetium	<b>Ru</b> 101.07 Ruthenium	<b>Rh</b> 102.906 Rhodium	<b>Ag</b> 107.868 Silver	<b>Cd</b> 112.41 Cadmium	<b>In</b> 114.82 Indium	<b>Sn</b> 118.71 Tin	<b>Sb</b> 121.763 Antimony	<b>Te</b> 127.60 Tellurium	<b>I</b> 126.904 Iodine	<b>Xe</b> 131.29 Xenon	<b>Xe</b> 131.29 Xenon	
6	<b>Cs</b> 132.905 Cesium	<b>Ba</b> 137.33 Barium	<b>La</b> 138.906 Lanthanum	<b>Hf</b> 178.49 Hafnium	<b>Ta</b> 180.948 Tantalum	<b>W</b> 183.84 Tungsten	<b>Re</b> 186.207 Rhenium	<b>Os</b> 190.23 Osmium	<b>Pt</b> 195.08 Platinum	<b>Au</b> 196.967 Gold	<b>Hg</b> 200.59 Mercury	<b>Tl</b> 204.383 Thallium	<b>Pb</b> 207.2 Lead	<b>Bi</b> 208.980 Bismuth	<b>Po</b> (209) Polonium	<b>At</b> (210) Astatine	<b>Rn</b> (222) Radon	<b>Rn</b> (222) Radon	
7	<b>Fr</b> (223) Francium	<b>Ra</b> 226.025 Radium	<b>Ac</b> 227.028 Actinium																
			Lanthanide Series																
			Actinide Series																

Mass numbers in parentheses are those of the most stable or most common isotope.



**DIRECTIONS**

Read each question and choose the best answer. Then fill in the correct answer on your answer document.

**SAMPLE A**

When a 10% hydrochloric acid solution is heated in an open test tube, the test tube should always be pointed —

- A so bubbles are visible
- B at a  $180^\circ$  angle from the flame
- C toward a ventilated area
- D away from nearby people

**SAMPLE B**

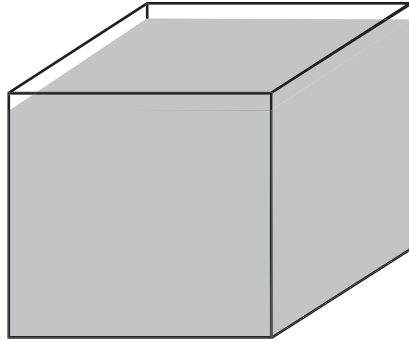

Mass = 40 g

Volume = 20 mL

The picture shows a cube that contains 20 mL of a solution. The solution has a mass of 40 grams. What is the density in g/mL of this solution? Record and bubble in your answer on the answer document.



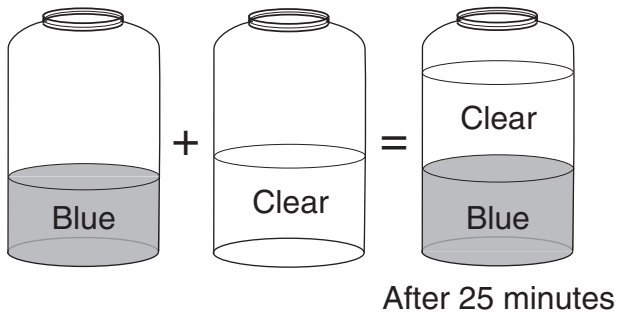

- 1 The picture shows the results of pouring a blue liquid into a clear liquid and allowing the mixture to settle for 25 minutes. Compared to the clear liquid, the blue liquid is more —
- A massive
  - B dense
  - C viscous
  - D soluble

- 2 The bacteria *Bacillus thuringiensis* produce protein crystals that are toxic to the digestive system of insects. How can these bacteria be used to control insects in crops?
- F Apply the bacteria to growing plants.
  - G Expose the bacteria to low levels of light.
  - H Remove plants from areas containing the bacteria.
  - J Treat the bacteria with a solution of the protein crystals.

## The Collared Peccary

The collared peccary is often mistaken for a pig. It has a short pig-like snout and crushing molars. The peccary has a mass of 10–20 kg and a shoulder height of about 50 cm.

The collared peccary is omnivorous, eating mostly roots, seeds, fruit, cacti, and occasionally insects and mice. Peccaries travel in herds of 6–30 animals. The natural enemies of the peccary are bobcats and coyotes.

- 3 Which of these is a food web based on the relationships described above?

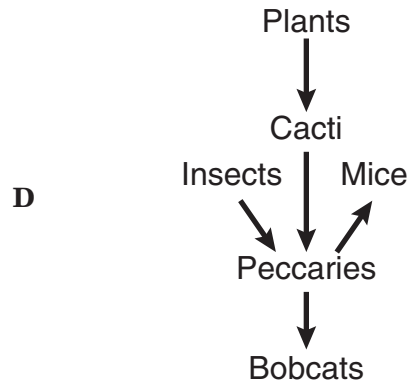
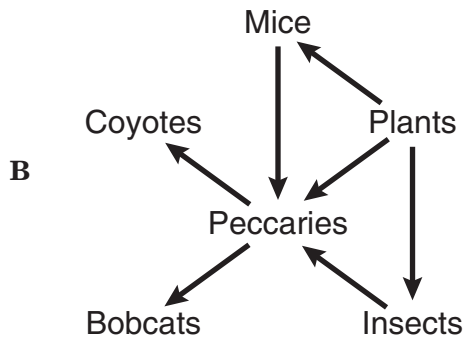
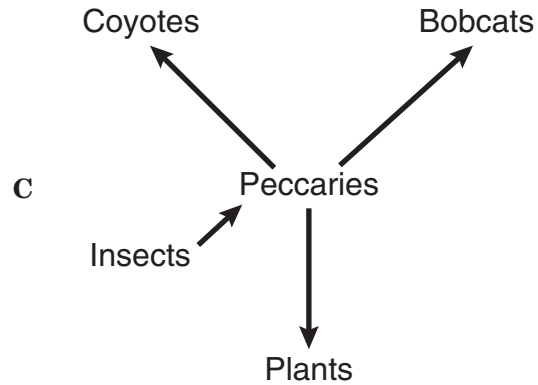
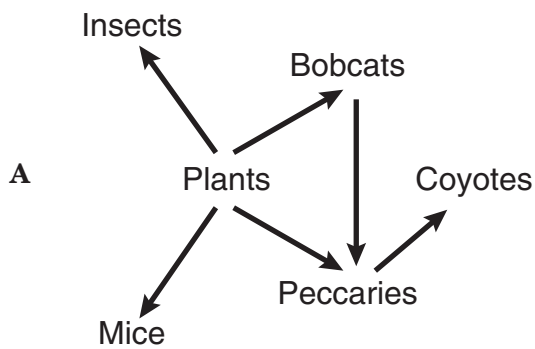



© Getty Images (29181.JPG)

- 4 This picture shows a small section of a solar power plant. Which of these decreases the energy production at such power plants?
- F Cloudy skies
  - G Ozone in the air
  - H Hot weather
  - J Low humidity

- 5 Which of these could be used to determine whether a substance is a base?
- A Thermometer
  - B Litmus paper
  - C Balance
  - D Bunsen burner

## Laser Light Striking a DVD

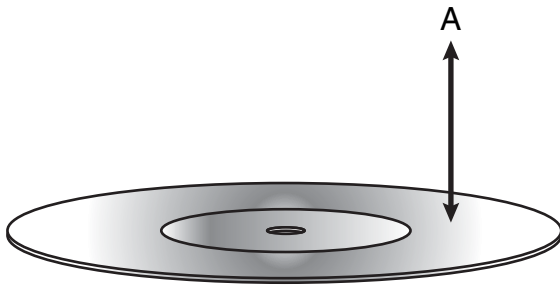

- 6 When a DVD is read, laser light touches the DVD surface and is then measured at location A. What allows light to return to location A after striking the DVD surface?

**F** Conduction  
**G** Refraction  
**H** Magnification  
**J** Reflection

- 7 Which of these best explains how mutation can be beneficial to an organism?
- A** Phenotypic change may create an advantage over other organisms.  
**B** Recombined genetic material improves genotype stability.  
**C** Mitosis becomes a favored means of reproduction.  
**D** Deoxyribose sugars develop into additional nucleotides.

## Kidneys and Dialysis

- Proteins and other large molecules cannot move through the membranes of healthy kidneys.
- The presence of large molecules in urine is an indication of unhealthy kidneys.
- Dialysis is a medical treatment that does the work for failing kidneys.
- In dialysis, an artificial membrane impermeable to large molecules is used.
- Dialysis lowers protein levels in urine.

- 8 The box contains some facts about kidneys and dialysis. Which of the following best explains why dialysis works?

**F** Dialysis reduces the size of proteins.  
**G** Proteins are dissolved by urine.  
**H** Dialysis filters proteins from solution.  
**J** Proteins transport membrane fragments.

- 9 The bonding characteristics of oxygen are most similar to the bonding characteristics of —

**A** hydrogen  
**B** silicon  
**C** helium  
**D** sulfur

**10** How is the excretory system most likely to respond when an animal is thirsty?

- F** By relaxing the smooth muscles
- G** By retaining body fluids
- H** By absorbing heat from lymph glands
- J** By releasing hormones

**11** Compounds with the same chemical composition may have different densities because they —

- A** have differences in reactivity
- B** are able to bond with oxygen
- C** vary in solubility
- D** exist in different phases

**12** An advertisement claims that a certain truck has the most powerful engine in its class. If the engine has more power, which of the following can the truck's engine do, compared to every other engine in its class?

- F** Produce fewer emissions
- G** Operate more efficiently
- H** Perform work faster
- J** Accelerate longer

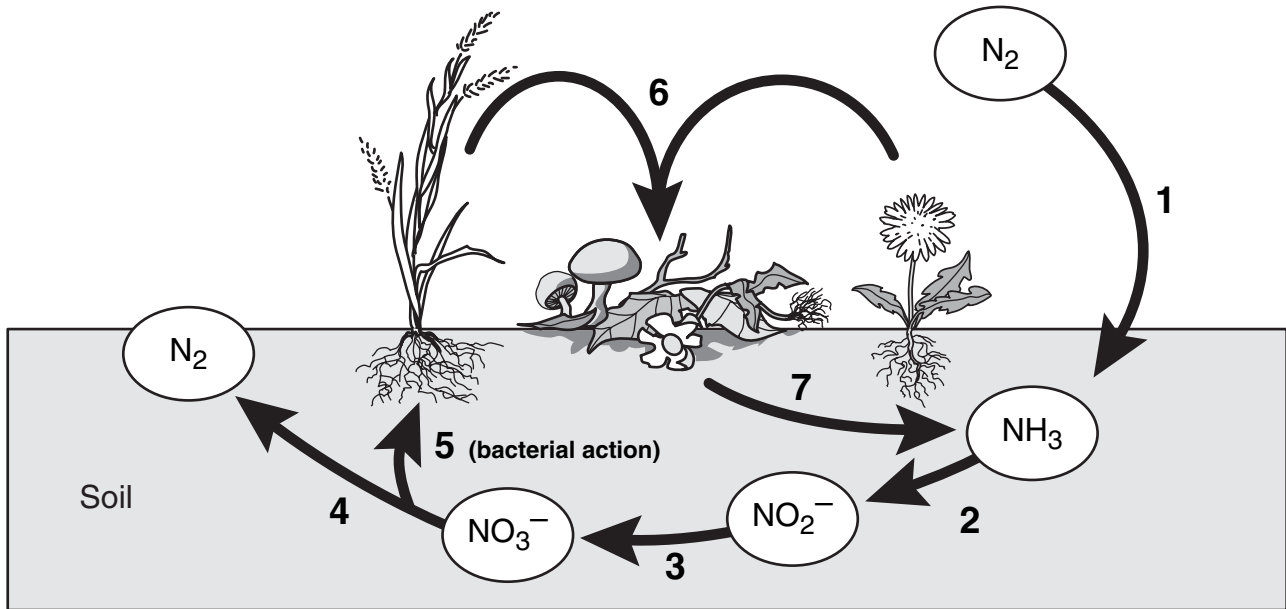

- 13 The diagram shows several phases of the nitrogen cycle. Which of the following describes the most likely effect of removing some plants from the area by using chemical herbicides?
- A The rate of erosion of rocks on the ground would be slowed.
  - B The flow of necessary nutrients would be disrupted.
  - C The ability of plants to complete photosynthesis would be increased.
  - D The infiltration of water into the ground would be halted.

14 Which of the following cannot metabolize nutrients?

F

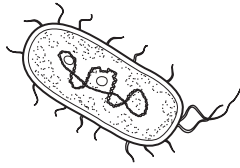

G

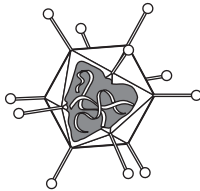

H

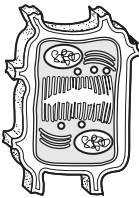

J

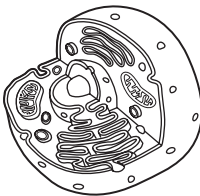

15 About 10% of the energy at one trophic level is passed to the next level. What usually happens to the energy that is not passed to the next trophic level or used to carry out life processes?

- A It is given off as heat.
- B It is stored as vitamins.
- C It is used in reproduction.
- D It is used in protein synthesis.

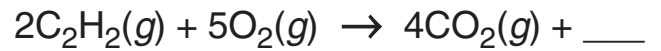

16 Which additional product balances this reaction?

- F  $4\text{OH}(aq)$
- G  $\text{CH}_4(g)$
- H  $\text{H}_2\text{O}_2(g)$
- J  $2\text{H}_2\text{O}(g)$

17 An empty cup was tightly covered with plastic wrap, and a few grains of salt were sprinkled on top of the plastic. When a tuning fork was struck and placed slightly above the plastic wrap, the salt began to move. Which characteristic of waves does the movement of the salt best demonstrate?

- A Echo formation
- B Diffraction
- C Resonance
- D Specular reflection

18 What is the net force exerted on a 90.0 kg race-car driver while the race car is accelerating from 0 to 44.7 m/s in 4.50 s?

- F 9.8 N
- G 20 N
- H 201 N
- J 894 N

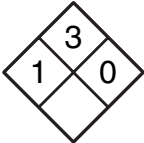
<b>Acetone</b> $C_3H_6O$	Generic Chemicals 1717 Industrial Row Anytown, USA 10059
Technical grade 500 mL CAS 67-64-1 	<ul style="list-style-type: none"><li>• Highly volatile</li><li>• Flammable liquid and vapor</li><li>• Respiratory irritant</li><li>• Harmful if swallowed or inhaled</li><li>• May cause injury to eyes</li><li>• Effects may be delayed</li></ul>

19 The label shown above contains information about some harmful effects of acetone. A group of students plans to use acetone to rinse out a glass container. A second group of students is working at the same lab table. Which of the following lab procedures should the second group of students avoid?

- A Heating water with an open flame
- B Pouring hydrochloric acid into a beaker
- C Filtering precipitates from a liquid solution
- D Collecting oxygen from plants in a test tube

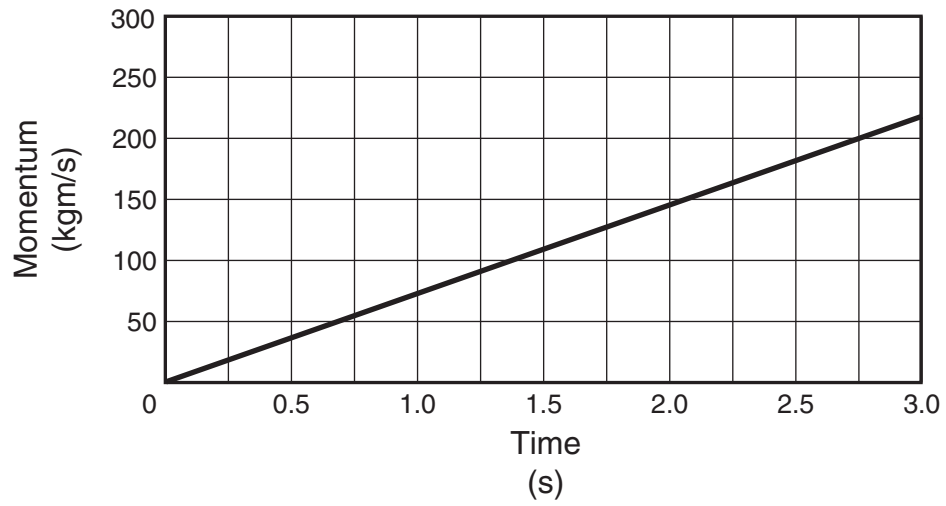

- 20 The graph shows how the momentum of a given mass changes during a period of motion. According to the information, what is the momentum in kg m/s at 2.75 seconds? Record and bubble in your answer to the nearest whole number on the answer document.

- 21** Power plants that discharge warm water into rivers have a negative effect on aquatic life. This is because the higher water temperature —
- A** increases the pressure of the river water
  - B** increases the pH value of the river water
  - C** decreases sediment solubility in the river water
  - D** decreases the dissolved oxygen in the river water

22 Which configuration of pulleys and belts shown below will result in the fastest rotation of Spindle 2?

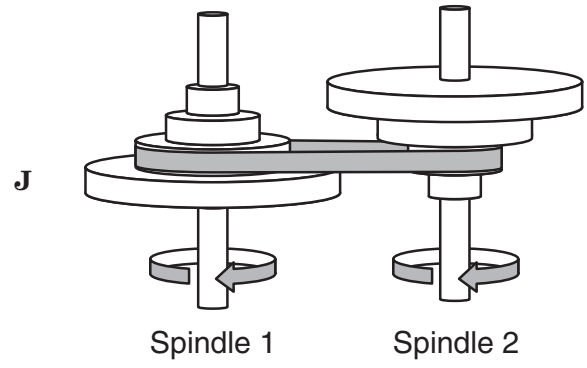
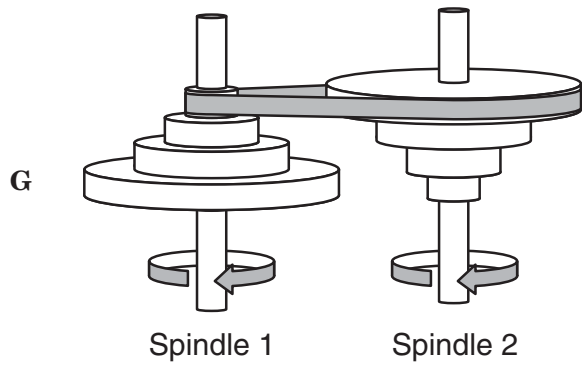
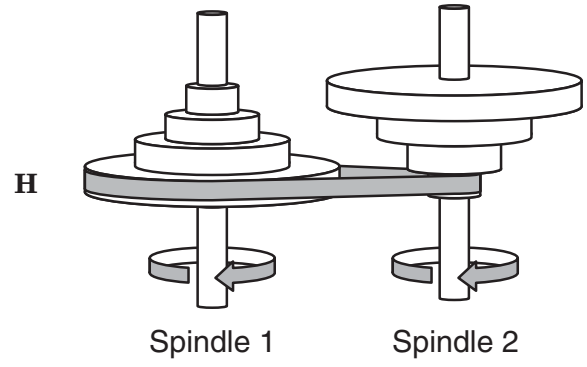
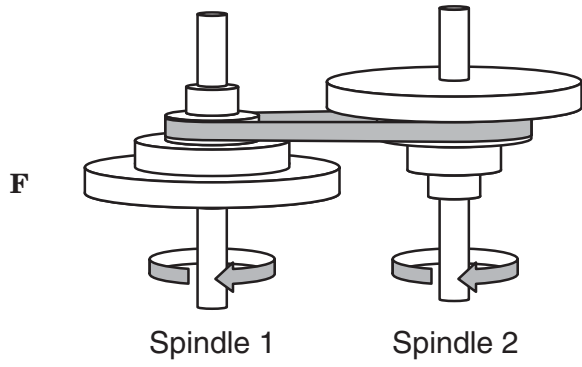

Liquid	Description	Density (g/mL)	Boiling Point (°C)
Q	Nonflammable colorless compound	1.62	59.5
R	Flammable colorless compound	0.71	34.6
S	Yellow mixture with strong odor	0.73	160.4
T	Viscous pale-yellow oil	0.93	300.0

23 The table shows properties of four liquids that are insoluble in water. If the four liquids are poured into an Erlenmeyer flask containing water, which liquid will form a layer below the water?

- A Q
- B R
- C S
- D T

### Voltage Required to Maintain Constant Current

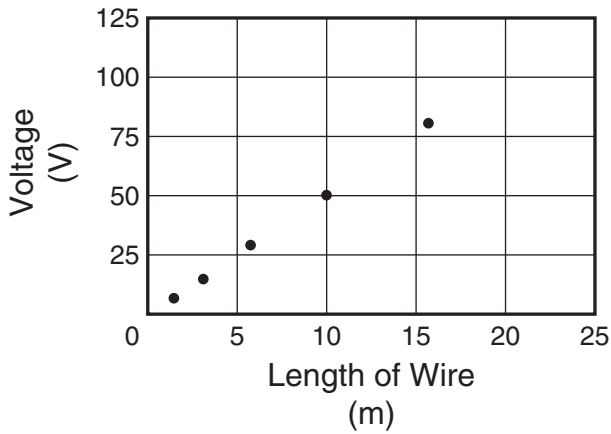

- 24 The graph shows how the voltage needed to maintain a constant current of 1.5 amps through a wire conductor varies with the length of the wire. If the trend continues, what is the most likely voltage needed to maintain a 1.5-amp current through 80 meters of the wire?
- F 10 volts
  - G 18 volts
  - H 250 volts
  - J 400 volts

- 25 Which characteristic of water best explains its ability to dissolve a great variety of materials?
- A Its transparency in light
  - B Its electrical conductivity
  - C Its physical state of matter
  - D Its molecular arrangement

Location	Corpus Christi	Fort Davis	Lipscomb
Latitude	27°48'N	30°35'N	36°14'N
Longitude	97°24'W	103°54'W	100°16'W
Elevation (m)	0 (sea level)	1494	728
Sanitizing Time (min)	20	25	22
Boiling Point of Water (°C)	100.0	95.0	97.6

- 26 Boiling water can be used to sanitize dishes. The data above show how sanitizing time varies in different locations. Which inference is supported by these data?
- F The boiling point of water is constant at higher altitudes.
  - G The boiling point of water is affected by elevation.
  - H Water takes longer to boil at Fort Davis than at sea level.
  - J Boiling water changes temperature at a faster rate at Corpus Christi than at higher elevations.

- 27 A medical researcher hypothesizes that a newly developed medication can reduce high blood pressure. Which of these would most likely be the dependent variable in a study involving this medication?
- A The number of participants in the study
  - B The ages of people treated for high blood pressure with other medications
  - C The blood pressure of the participants in the study
  - D The number of people treated for high blood pressure with other medications

Boyle's law gives the relationship between the pressure and volume of a gas if the temperature and mass of the gas are held constant:

- If the volume of the gas is increased, the pressure of the gas decreases.
- If the volume of the gas is decreased, the pressure of the gas increases.

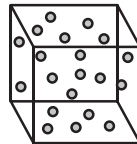

Temp. = 20°C  
Pressure = 10 atm

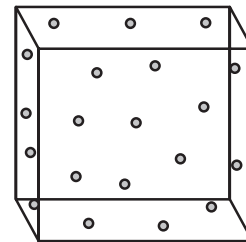

Temp. = 20°C  
Pressure = 2.5 atm

28 What can be concluded from the relationships described above?

- F** Gas molecules travel longer distances at greater speeds when the volume of the gas is decreased.
- G** A gas is more likely to lose kinetic energy when its volume is reduced.
- H** Gas molecules collide less frequently when the volume of the gas is increased.
- J** A gas is more likely to increase in momentum when its volume is increased.

29 Which of these represents a properly balanced system?

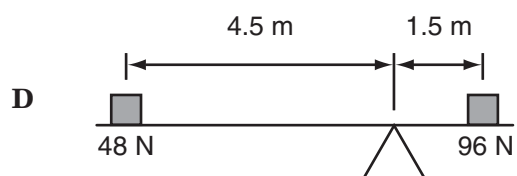
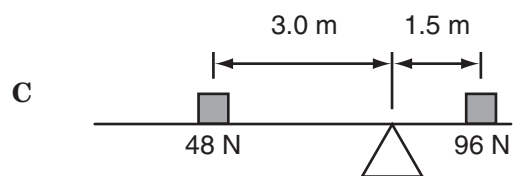
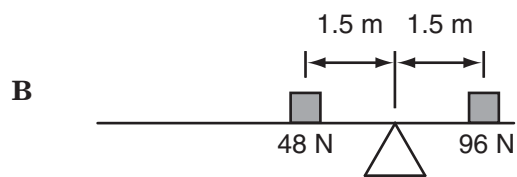
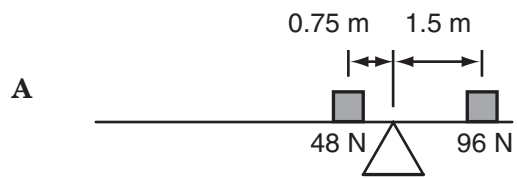

### Variation in Leaf-Dropping Times

Plot	Gases Added to Surrounding Air	Time (days)
1	CO <sub>2</sub>	26
2	O <sub>3</sub>	3
3	CO <sub>2</sub> + O <sub>3</sub> mixture	10
4	None (control)	18

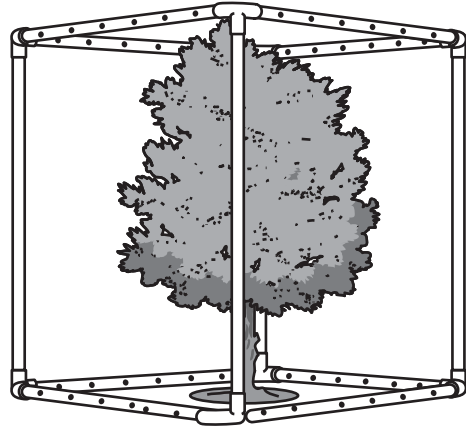

- 30** The table shows the time it took trees of the same type and size to drop all of their leaves after being grown in different atmospheres. For the experiment to be valid, which of these must be a constant for all the trees?
- F** The height of all the trees during the entire experiment
  - G** The amount of water available to all trees during the experiment
  - H** The mass of fallen leaves collected from each tree
  - J** The rate of photosynthesis in all trees during the experiment

- 31** Sickle-cell anemia is a disorder resulting from a mutation that leads to the production of an abnormal protein. Which component of the DNA molecule provides instructions for the production of the protein?
- A** The phosphate groups
  - B** The sugar molecules
  - C** The sequence of nitrogen bases
  - D** The bonds that hold the sugars to the bases

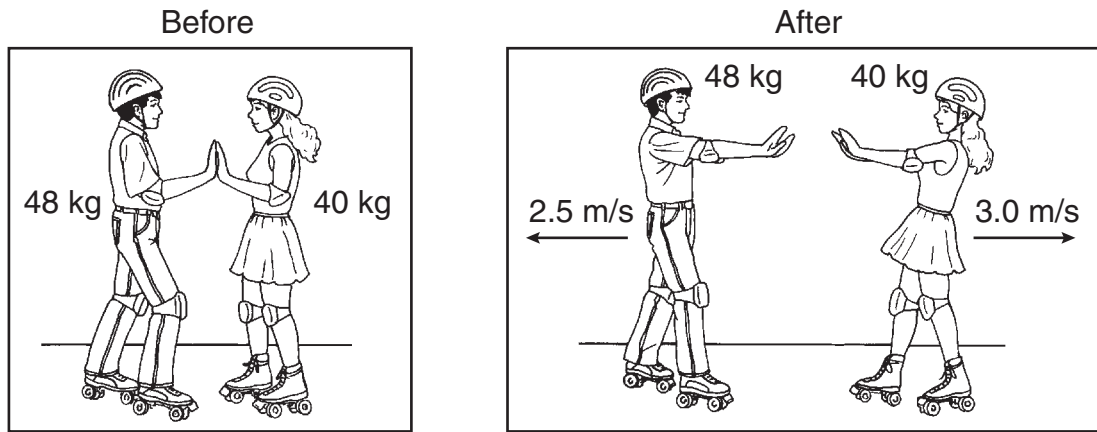

**32** Starting from rest at the center of a skating rink, two skaters push off from each other over a time period of 1.2 s. What is the force of the push by the smaller skater?

- F** 16 N
- G** 32 N
- H** 88 N
- J** 100 N

Use the information below and your knowledge of science to answer questions 33–35.

## Louis Pasteur’s Experiment

Like many other scientific breakthroughs, the discovery of immunization happened by accident.

In 1880 Louis Pasteur was trying to protect chickens from cholera. To study the disease, Pasteur and his assistants gave injections of cholera bacteria to several groups of chickens. The chickens usually died from cholera after being injected with the bacteria. However, one group of chickens survived. Pasteur noticed that these chickens had been injected with a six-week-old batch of cholera bacteria.

Pasteur’s assistants prepared new colonies of cholera bacteria and injected these chickens a second time. They also injected a group of chickens that had not been previously injected. Pasteur was surprised that the chickens that had been injected previously with the old bacteria remained healthy, while all the chickens in the second group became sick and died.

This is how Pasteur came to discover that exposure to weakened pathogens can provide immunity from disease. The idea was later used to protect animals from other serious diseases. Today immunizations help protect people from many illnesses.

- 33** Which of these probably served as the most useful data after Pasteur injected a group of chickens with bacteria from the older culture?
- A** The health and behavior of the injected chickens
  - B** The total number of cholera cases observed
  - C** The changes in the shape and color of the bacterial colonies
  - D** The recovery rate of chickens previously infected with cholera

Cholera-causing bacteria belong to the genus *Vibrio*. Some species of *Vibrio* cause diseases in chickens and humans. However, some species have mutualistic relationships with fish and other marine life.

- 34** Which of these is the best example of a mutualistic relationship in an aquatic environment?
- F** Some fish can survive repeated infections by harmful bacteria.
  - G** Some fish have bacteria living in their digestive tract that help the fish digest food.
  - H** Some bacteria are present in aquatic food chains in which fish are secondary consumers.
  - J** Some bacteria are aquatic decomposers that recycle nutrients useful to fish.
- 35** Cholera-causing bacteria have a single flagellum that allows these bacteria to —
- A** move
  - B** reproduce
  - C** excrete water
  - D** produce sugar

Group	Temperature (°C)	Solubility (g/100 mL)
A	0	28
B	10	31
C	20	34
D	30	37
E	40	40
F	60	45
G	80	51
H	90	54
I	100	56

36 Nine groups of students dissolved as much potassium chloride as possible in water. Each group used 100 mL of water heated to a different temperature. Which graph shows the relationship between solubility and temperature for potassium chloride?

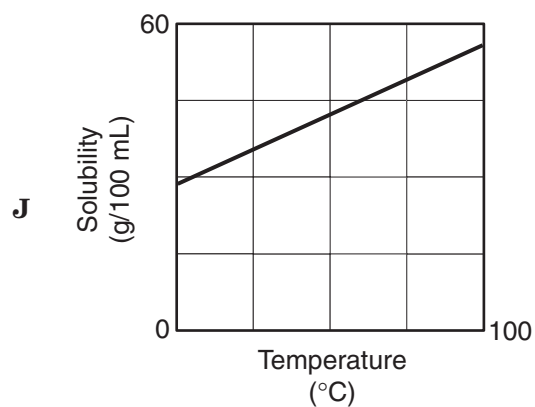
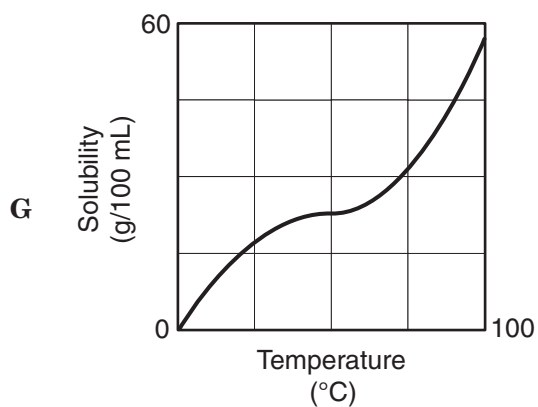
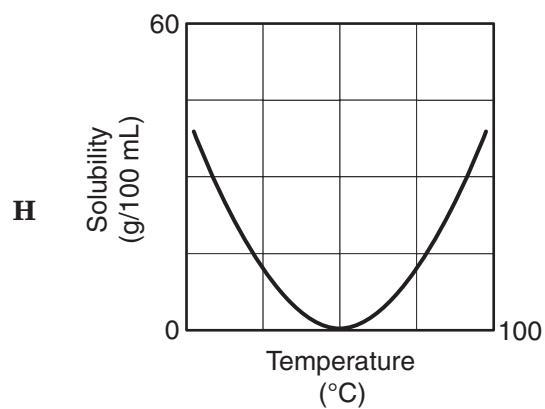
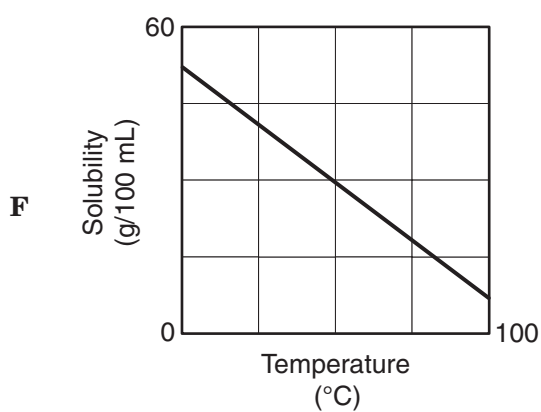

37 Which of these produces most of the compounds responsible for causing acid rain?

- A Nuclear fission
- B Fossil fuels
- C Solar cells
- D Windmills

38 Which of these elements is most likely to donate one electron?

- F Be
- G Cs
- H Rn
- J He

Effectiveness of Horse Medication

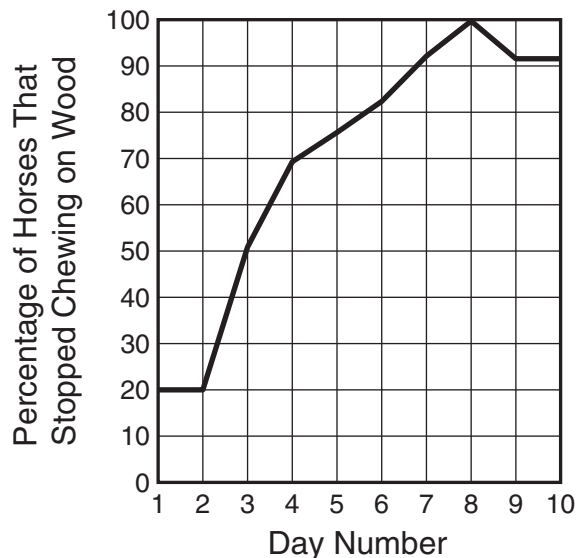

39 Horses kept in stables sometimes chew on wood. This can lead to damage to the mouth and digestive system. The graph shows the results of a study of a medication that prevents horses from chewing on wood. From the graph, what inference can be made about the effectiveness of the product?

- A Most horses like the medication.
- B The medication is most effective between Days 4 and 5.
- C Most horses will show improvement within 7 days.
- D The effects of the medication are long lasting.

- 40** In all plant and animal cells, the nucleus contains long molecules of DNA. Which of the following best describes the function of DNA?
- F** DNA provides the shape and structure of the nucleus.
  - G** DNA packages materials for transport through the nucleus.
  - H** DNA carries materials into and out of the nucleus.
  - J** DNA contains the blueprint for producing the whole organism.

- 41** The following hypothesis refers to iron in the topsoil found on an island formed from limestone.

Hypothesis: Much of the iron found in the topsoil of the island was carried from Africa by huge dust clouds.

Which study would most likely be used to investigate this hypothesis?

- A** Tracking dust clouds with satellite photos
- B** Determining the effects of iron on limestone
- C** Calculating erosion rates in African limestone mines
- D** Analyzing the content of comet dust clouds

- 42 Alpha particles are one type of radioactivity. These particles have a nucleus of two protons and two neutrons but have no orbital electrons. Based on this information, it can be inferred that alpha particles are positive ions of the element —

- F actinium
- G curium
- H radium
- J helium

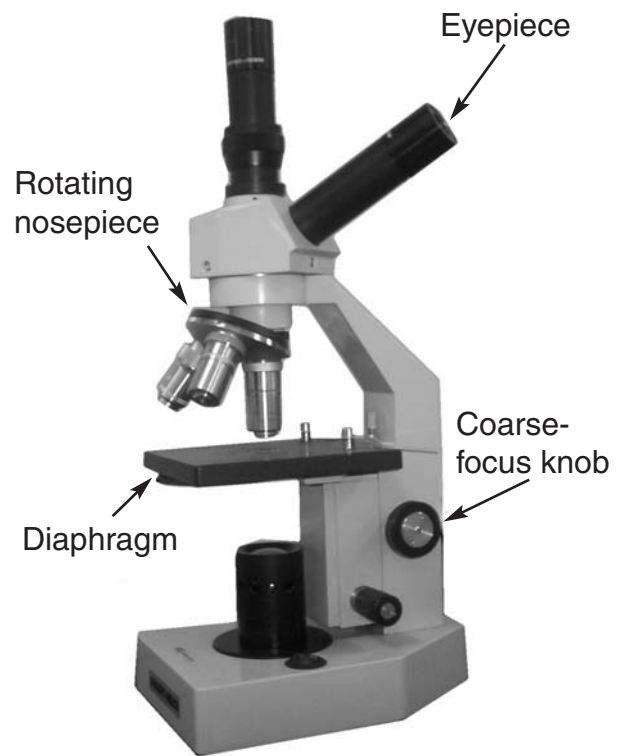

- 43 The picture above shows a compound microscope. What part of the microscope should be used to adjust the amount of light illuminating a prepared slide?
- A Eyepiece
  - B Rotating nosepiece
  - C Diaphragm
  - D Coarse-focus knob

About 10,000 years ago two populations of tassel-eared squirrels were separated from each other. Today these squirrels are so different that they are unable to interbreed when brought together.

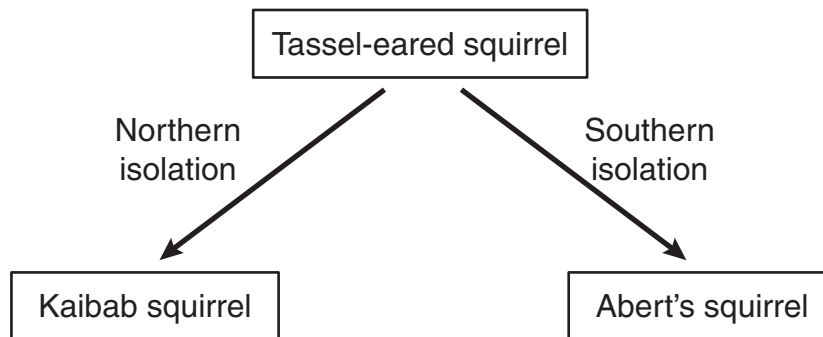

44 Which of the following explains this phenomenon?

- F Competition
- G Extinction
- H Predation
- J Speciation

45 Erwin Chargaff studied the DNA of organisms within a single species. Chargaff discovered that the amount of adenine is about equal to the amount of thymine. Which of these explains why the ratio of adenine to thymine is nearly 1:1?

- A Adenine and thymine pair with each other.
- B Adenine binds with phosphates, while thymine binds with nitrates.
- C Adenine and thymine are identical in chemical composition.
- D Adenine bases contain a form of thymine.

### Electron Configuration

Energy level	1	2	3
Electrons	2	8	8

46 According to the periodic table and the information above, which element has this electron configuration?

- F Sodium
- G Neon
- H Magnesium
- J Argon

- 47 Which of these does a virus need in order to multiply?
- A Chloroplasts from a host cell
  - B A host cell to provide oxygen for the virus
  - C New ADP from a host cell
  - D A host cell to replicate the virus's DNA

Trade winds blow from east to west across the Pacific Ocean. The winds move surface waters westward across the ocean. This causes deeper, colder water to rise to the surface along the coast. This upwelling of deep ocean waters brings with it nutrients that would otherwise lie near the bottom of the ocean.

- 48 Which of the following conclusions is supported by the information above?
- F Trade winds help maintain some food chains.
  - G Trade winds produce useful minerals in some oceans.
  - H Trade winds can reverse parts of the water cycle.
  - J Trade winds may be able to reduce greenhouse gases.

- 49 Which of these best explains why a freshwater aquarium would be a dangerous habitat for saltwater fish?
- A The tissues of the saltwater fish would absorb too much acid.
  - B The organs of the saltwater fish would produce too much protein.
  - C The organ systems of the saltwater fish would consume too much energy.
  - D The cells of the saltwater fish would gain too much water.

50 Which lever requires the least effort to lift the load?

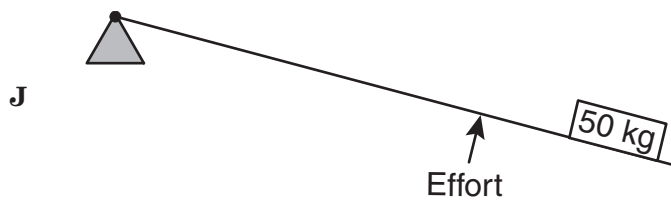
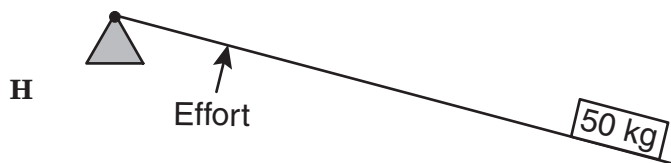
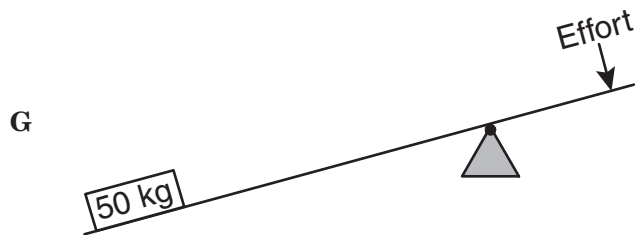
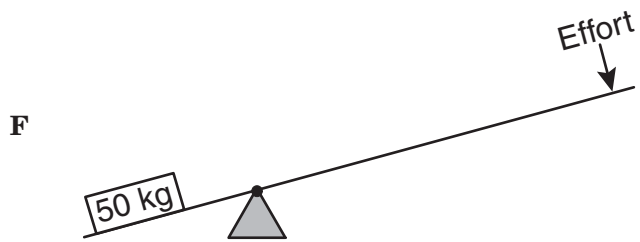

Conclusion: Hearing aids are an effective way to treat hearing loss.

- 51** A study was conducted to test the effectiveness of hearing aids. People with different types of hearing loss were included in the study. Which question would help in determining whether the conclusion above is valid?
- A** What was the average age of the people in the study?
  - B** What was the most common occupation of people in the study?
  - C** How many people were included in the study?
  - D** How many people in the study had vision problems?
- 52** When the air is released from a balloon, the air moves in one direction, and the balloon moves in another direction. Which statement does this situation best illustrate?
- F** What goes up must come down.
  - G** For every action there is an equal and opposite reaction.
  - H** The shape and size of an object affect air resistance.
  - J** The acceleration due to Earth's gravity is  $9.8 \text{ m/s}^2$ .
- 53** A certain atom has a nucleus containing six protons and eight neutrons and has six electrons orbiting the nucleus. This atom is a form of the element —
- A** silicon
  - B** carbon
  - C** magnesium
  - D** calcium

**54** The myxoma virus was used to control an overpopulation of European rabbits in Australia. When first introduced in the mid-1900s, the virus greatly reduced the European rabbit population. Today the virus is not an effective control of the European rabbit population. Fewer European rabbits are affected by the virus today because they have —

- F** learned to avoid the virus
- G** moved away from infected areas
- H** undergone a change in diet
- J** developed resistance to the virus

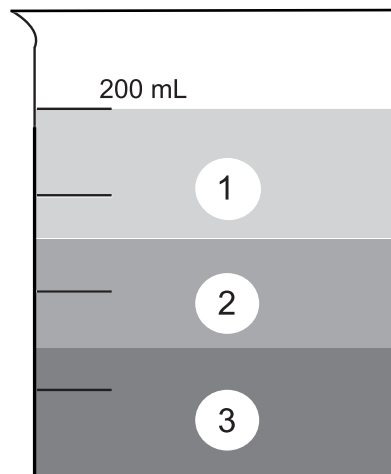

- 55** Three liquids were poured into a beaker and formed three layers. Which conclusion is best supported by the information above?
- A** The mass of Liquid 2 is greater than the mass of Liquid 3.
  - B** The volume of Liquid 1 is less than the volume of Liquid 3.
  - C** The density of Liquid 3 is greater than the density of Liquid 2.
  - D** The buoyancy of Liquid 2 is greater than the buoyancy of Liquid 1.

BE SURE YOU HAVE RECORDED ALL OF YOUR ANSWERS  
ON THE ANSWER DOCUMENT.



