

# Installing the BayStack 150/152 Ethernet Hub Boot Firmware

4401 Great America Parkway  
Santa Clara, CA 95054

8 Federal Street  
Billerica, MA 01821

Part No. 203372-A  
October 1998



Bay Networks

\*203372-A\*

## Copyright © 1998 Bay Networks, Inc.

All rights reserved. Printed in the USA. October 1998.

The information in this document is subject to change without notice. The statements, configurations, technical data, and recommendations in this document are believed to be accurate and reliable, but are presented without express or implied warranty. Users must take full responsibility for their applications of any products specified in this document. The information in this document is proprietary to Bay Networks, Inc.

The software described in this document is furnished under a license agreement and may only be used in accordance with the terms of that license. A summary of the Software License is included in this document.

### Trademarks

Bay Networks is a registered trademark and BayStack is a trademark of Bay Networks, Inc.

### Statement of Conditions

In the interest of improving internal design, operational function, and/or reliability, Bay Networks, Inc. reserves the right to make changes to the products described in this document without notice.

Bay Networks, Inc. does not assume any liability that may occur due to the use or application of the product(s) or circuit layout(s) described herein.

Portions of the code in this software product are Copyright © 1988, Regents of the University of California. All rights reserved. Redistribution and use in source and binary forms of such portions are permitted, provided that the above copyright notice and this paragraph are duplicated in all such forms and that any documentation, advertising materials, and other materials related to such distribution and use acknowledge that such portions of the software were developed by the University of California, Berkeley. The name of the University may not be used to endorse or promote products derived from such portions of the software without specific prior written permission.

SUCH PORTIONS OF THE SOFTWARE ARE PROVIDED "AS IS" AND WITHOUT ANY EXPRESS OR IMPLIED WARRANTIES, INCLUDING, WITHOUT LIMITATION, THE IMPLIED WARRANTIES OF MERCHANTABILITY AND FITNESS FOR A PARTICULAR PURPOSE.

In addition, the program and information contained herein are licensed only pursuant to a license agreement that contains restrictions on use and disclosure (that may incorporate by reference certain limitations and notices imposed by third parties).

### Bay Networks, Inc. Software License Agreement

**NOTICE:** Please carefully read this license agreement before copying or using the accompanying software or installing the hardware unit with pre-enabled software (each of which is referred to as "Software" in this Agreement). BY COPYING OR USING THE SOFTWARE, YOU ACCEPT ALL OF THE TERMS AND CONDITIONS OF THIS LICENSE AGREEMENT. THE TERMS EXPRESSED IN THIS AGREEMENT ARE THE ONLY TERMS UNDER WHICH BAY NETWORKS WILL PERMIT YOU TO USE THE SOFTWARE. If you do not accept these terms and conditions, return the product, unused and in the original shipping container, within 30 days of purchase to obtain a credit for the full purchase price.

---

**1. License Grant.** Bay Networks, Inc. (“Bay Networks”) grants the end user of the Software (“Licensee”) a personal, nonexclusive, nontransferable license: a) to use the Software either on a single computer or, if applicable, on a single authorized device identified by host ID, for which it was originally acquired; b) to copy the Software solely for backup purposes in support of authorized use of the Software; and c) to use and copy the associated user manual solely in support of authorized use of the Software by Licensee. This license applies to the Software only and does not extend to Bay Networks Agent software or other Bay Networks software products. Bay Networks Agent software or other Bay Networks software products are licensed for use under the terms of the applicable Bay Networks, Inc. Software License Agreement that accompanies such software and upon payment by the end user of the applicable license fees for such software.

**2. Restrictions on use; reservation of rights.** The Software and user manuals are protected under copyright laws. Bay Networks and/or its licensors retain all title and ownership in both the Software and user manuals, including any revisions made by Bay Networks or its licensors. The copyright notice must be reproduced and included with any copy of any portion of the Software or user manuals. Licensee may not modify, translate, decompile, disassemble, use for any competitive analysis, reverse engineer, distribute, or create derivative works from the Software or user manuals or any copy, in whole or in part. Except as expressly provided in this Agreement, Licensee may not copy or transfer the Software or user manuals, in whole or in part. The Software and user manuals embody Bay Networks’ and its licensors’ confidential and proprietary intellectual property. Licensee shall not sublicense, assign, or otherwise disclose to any third party the Software, or any information about the operation, design, performance, or implementation of the Software and user manuals that is confidential to Bay Networks and its licensors; however, Licensee may grant permission to its consultants, subcontractors, and agents to use the Software at Licensee’s facility, provided they have agreed to use the Software only in accordance with the terms of this license.

**3. Limited warranty.** Bay Networks warrants each item of Software, as delivered by Bay Networks and properly installed and operated on Bay Networks hardware or other equipment it is originally licensed for, to function substantially as described in its accompanying user manual during its warranty period, which begins on the date Software is first shipped to Licensee. If any item of Software fails to so function during its warranty period, as the sole remedy Bay Networks will at its discretion provide a suitable fix, patch, or workaround for the problem that may be included in a future Software release. Bay Networks further warrants to Licensee that the media on which the Software is provided will be free from defects in materials and workmanship under normal use for a period of 90 days from the date Software is first shipped to Licensee. Bay Networks will replace defective media at no charge if it is returned to Bay Networks during the warranty period along with proof of the date of shipment. This warranty does not apply if the media has been damaged as a result of accident, misuse, or abuse. The Licensee assumes all responsibility for selection of the Software to achieve Licensee’s intended results and for the installation, use, and results obtained from the Software. Bay Networks does not warrant a) that the functions contained in the software will meet the Licensee’s requirements, b) that the Software will operate in the hardware or software combinations that the Licensee may select, c) that the operation of the Software will be uninterrupted or error free, or d) that all defects in the operation of the Software will be corrected. Bay Networks is not obligated to remedy any Software defect that cannot be reproduced with the latest Software release. These warranties do not apply to the Software if it has been (i) altered, except by Bay Networks or in accordance with its instructions; (ii) used in conjunction with another vendor’s product, resulting in the defect; or (iii) damaged by improper environment, abuse, misuse, accident, or negligence. THE FOREGOING WARRANTIES AND LIMITATIONS ARE EXCLUSIVE REMEDIES AND ARE IN LIEU OF ALL OTHER WARRANTIES EXPRESS OR IMPLIED, INCLUDING WITHOUT LIMITATION ANY WARRANTY OF MERCHANTABILITY OR FITNESS FOR A PARTICULAR PURPOSE. Licensee is responsible for the security of its own data and information and for maintaining adequate procedures apart from the Software to reconstruct lost or altered files, data, or programs.

**4. Limitation of liability.** IN NO EVENT WILL BAY NETWORKS OR ITS LICENSORS BE LIABLE FOR ANY COST OF SUBSTITUTE PROCUREMENT; SPECIAL, INDIRECT, INCIDENTAL, OR CONSEQUENTIAL DAMAGES; OR ANY DAMAGES RESULTING FROM INACCURATE OR LOST DATA OR LOSS OF USE OR PROFITS ARISING OUT OF OR IN CONNECTION WITH THE PERFORMANCE OF THE SOFTWARE, EVEN IF BAY NETWORKS HAS BEEN ADVISED OF THE POSSIBILITY OF SUCH DAMAGES. IN NO EVENT SHALL THE LIABILITY OF BAY NETWORKS RELATING TO THE SOFTWARE OR THIS AGREEMENT EXCEED THE PRICE PAID TO BAY NETWORKS FOR THE SOFTWARE LICENSE.

---

**5. Government Licensees.** This provision applies to all Software and documentation acquired directly or indirectly by or on behalf of the United States Government. The Software and documentation are commercial products, licensed on the open market at market prices, and were developed entirely at private expense and without the use of any U.S. Government funds. The license to the U.S. Government is granted only with restricted rights, and use, duplication, or disclosure by the U.S. Government is subject to the restrictions set forth in subparagraph (c)(1) of the Commercial Computer Software—Restricted Rights clause of FAR 52.227-19 and the limitations set out in this license for civilian agencies, and subparagraph (c)(1)(ii) of the Rights in Technical Data and Computer Software clause of DFARS 252.227-7013, for agencies of the Department of Defense or their successors, whichever is applicable.

**6. Use of Software in the European Community.** This provision applies to all Software acquired for use within the European Community. If Licensee uses the Software within a country in the European Community, the Software Directive enacted by the Council of European Communities Directive dated 14 May, 1991, will apply to the examination of the Software to facilitate interoperability. Licensee agrees to notify Bay Networks of any such intended examination of the Software and may procure support and assistance from Bay Networks.

**7. Term and termination.** This license is effective until terminated; however, all of the restrictions with respect to Bay Networks' copyright in the Software and user manuals will cease being effective at the date of expiration of the Bay Networks copyright; those restrictions relating to use and disclosure of Bay Networks' confidential information shall continue in effect. Licensee may terminate this license at any time. The license will automatically terminate if Licensee fails to comply with any of the terms and conditions of the license. Upon termination for any reason, Licensee will immediately destroy or return to Bay Networks the Software, user manuals, and all copies. Bay Networks is not liable to Licensee for damages in any form solely by reason of the termination of this license.

**8. Export and Re-export.** Licensee agrees not to export, directly or indirectly, the Software or related technical data or information without first obtaining any required export licenses or other governmental approvals. Without limiting the foregoing, Licensee, on behalf of itself and its subsidiaries and affiliates, agrees that it will not, without first obtaining all export licenses and approvals required by the U.S. Government: (i) export, re-export, transfer, or divert any such Software or technical data, or any direct product thereof, to any country to which such exports or re-exports are restricted or embargoed under United States export control laws and regulations, or to any national or resident of such restricted or embargoed countries; or (ii) provide the Software or related technical data or information to any military end user or for any military end use, including the design, development, or production of any chemical, nuclear, or biological weapons.

**9. General.** If any provision of this Agreement is held to be invalid or unenforceable by a court of competent jurisdiction, the remainder of the provisions of this Agreement shall remain in full force and effect. This Agreement will be governed by the laws of the state of California.

Should you have any questions concerning this Agreement, contact Bay Networks, Inc., 4401 Great America Parkway, P.O. Box 58185, Santa Clara, California 95054-8185.

LICENSEE ACKNOWLEDGES THAT LICENSEE HAS READ THIS AGREEMENT, UNDERSTANDS IT, AND AGREES TO BE BOUND BY ITS TERMS AND CONDITIONS. LICENSEE FURTHER AGREES THAT THIS AGREEMENT IS THE ENTIRE AND EXCLUSIVE AGREEMENT BETWEEN BAY NETWORKS AND LICENSEE, WHICH SUPERSEDES ALL PRIOR ORAL AND WRITTEN AGREEMENTS AND COMMUNICATIONS BETWEEN THE PARTIES PERTAINING TO THE SUBJECT MATTER OF THIS AGREEMENT. NO DIFFERENT OR ADDITIONAL TERMS WILL BE ENFORCEABLE AGAINST BAY NETWORKS UNLESS BAY NETWORKS GIVES ITS EXPRESS WRITTEN CONSENT, INCLUDING AN EXPRESS WAIVER OF THE TERMS OF THIS AGREEMENT.

---

## Introduction

This publication explains how to upgrade the boot firmware on Bay Networks® BayStack™ 150 Ethernet hubs and BayStack 152 Ethernet hubs. In this publication these hubs are referred to collectively as the BayStack 150/152 Ethernet hubs. This boot firmware upgrade is required only for the BayStack 150/152 Ethernet hubs. It is not required for other BayStack 150-series products.

For more information about the hub, refer to the following publication:

- *Installation and Reference for the BayStack 150-series Ethernet Hubs* (Bay Networks part number 893-01021-B)



**Caution:** Only qualified technicians should install and service this equipment, including performing this upgrade.

---

This product contains devices that are sensitive to electrostatic discharge (ESD). Place the hub on an antistatic mat when you perform the upgrade. If you do not have an antistatic mat, make sure you discharge any accumulated static electricity, or wear a discharge leash, when handling boards and boot firmware. Otherwise, you risk damaging the components.

## Required Tools

To replace the BayStack 150/152 Ethernet Hub boot firmware, you need the following tools:

- A Phillips-head screwdriver for removing and replacing the retaining screws on the hub exterior
- A hex-head screwdriver for removing and replacing hex-head screws in the comm port
- BayStack 150/152 Ethernet hub power cable

## Package Contents

This upgrade kit contains the following items:

- Boot firmware (part number ATMEL 27C010) (qty 1)
- Chip puller (qty 1)

## Disassembling the BayStack 150/152 Ethernet Hub

Before disassembling the hub to remove and replace the boot firmware, take the necessary precautions to ensure that user sessions are not disrupted and that appropriate safety measures have been followed.

To disassemble the BayStack 150/152 Ethernet hub:

1. **Place the hub on a level surface, with the front of the hub facing you** ([Figure 1](#)).

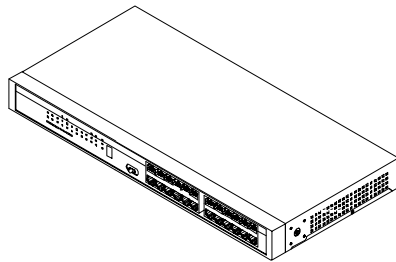

**Figure 1. Front and Top Views of the BayStack 150/152 Ethernet Hub**

2. **Remove the top panel:**
  - a. **Using the Phillips-head screwdriver, remove two flat-head screws each from the left, right, and rear of the hub** ([Figure 2](#)).
  - b. **Using the hex-head screwdriver, remove two hex-head screws from the comm port on the rear of the hub** ([Figure 2](#)).

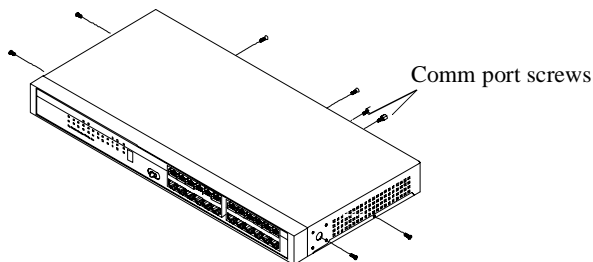

**Figure 2. Exterior Screw Locations**

- c. Lift the top panel off ([Figure 3](#)).

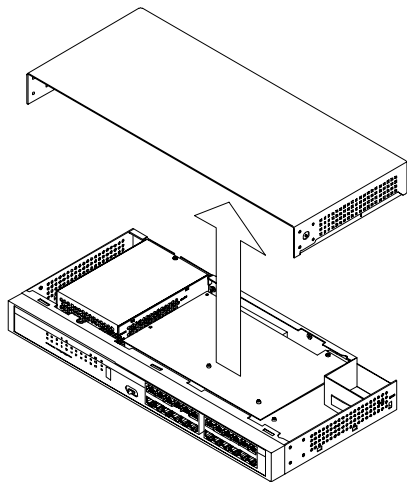

**Figure 3. Removing the Top Panel**

**3. Remove the upper board:**

- a. Loosen the four head pins from the upper board ([Figure 4](#)).

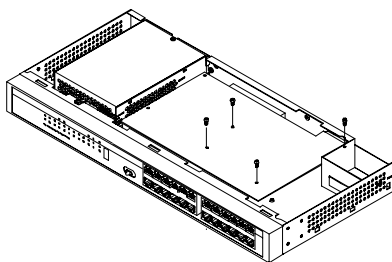

**Figure 4. Head Pin Locations on the Top of the Board**

- b. Firmly lift the board up, disconnecting the male parts of the head pins from the female parts.

- c. **Completely remove the board.**
- d. **Turn the board over to reveal the side containing the socket and firmware ([Figure 5](#)).**

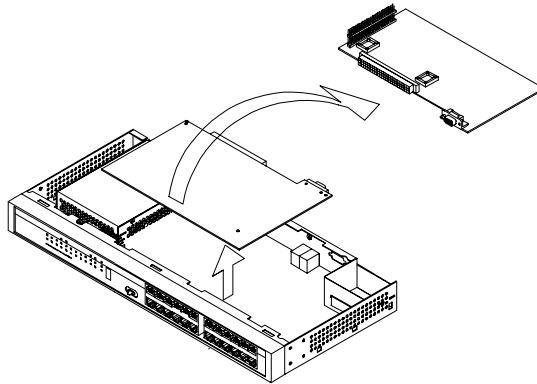
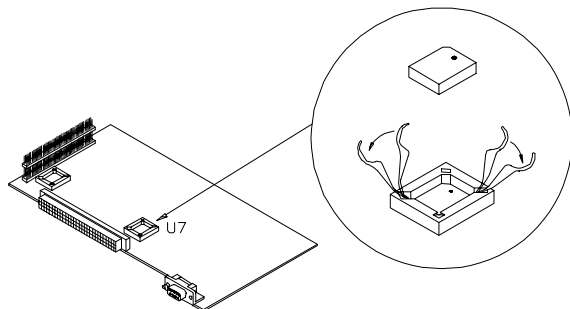

**Figure 5. Removing the Board**

## Replacing the Boot Firmware

To replace the boot firmware in the BayStack 150/152 Ethernet hub:

1. Using the chip puller, remove the boot firmware (part number IC27C010) from the U7 socket ([Figure 6](#)).



**Figure 6. Removing the U7 Chip from the Socket**

2. Discard this chip.
3. Insert the first pin of the new boot firmware (part number ATMEL 27C010) into the triangle symbol in the U7 socket, or align the chip with the socket and insert it into the U7 socket ([Figure 7](#)).

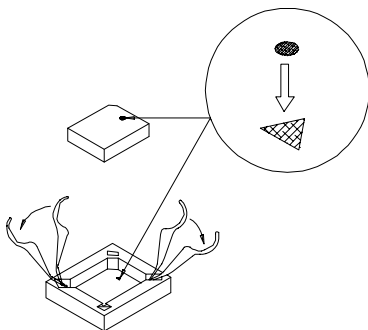

**Figure 7. Aligning the Chip in the Socket**

4. Carefully press the chip into place, until it lies flat and evenly inside the socket.
5. Replace the upper board:
  - a. Align the upper board with the interior of the hub ([Figure 8](#)).

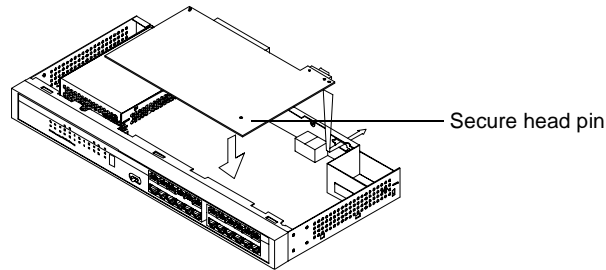

**Figure 8. Replacing the Upper Board**

- b. Align the comm port on the board with the comm port in the hub interior.
- c. Secure the male head pin on the left edge of the board with the female head pin on the left interior of the hub.

## Verifying the New Boot Firmware

Before using the BayStack 150/152 Ethernet hub with its new boot firmware, test the new assembly to be sure the following sequence occurs:

1. **Plug the BayStack 150/152 Ethernet hub power cable into the port on the rear of the hub.**
2. **Plug the other end of the power cable into a power source.**
3. **Verify the proper functioning of the new boot firmware:**
  - The Utilization light flashes in one location, for instance Location 1. ([Figure 9](#)).

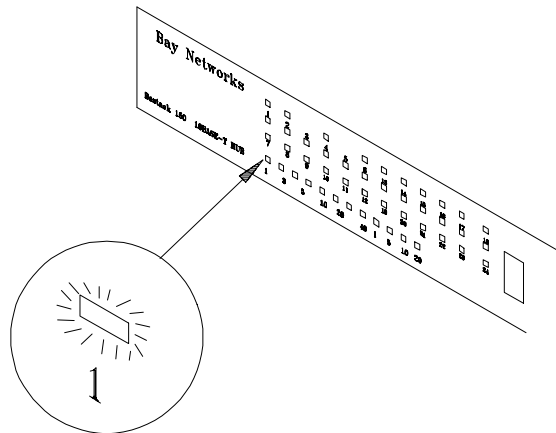

**Figure 9. Utilization Light 1 Location**

- The Link light flashes between two ports, for instance between ports 1 and 7 ([Figure 10](#)).

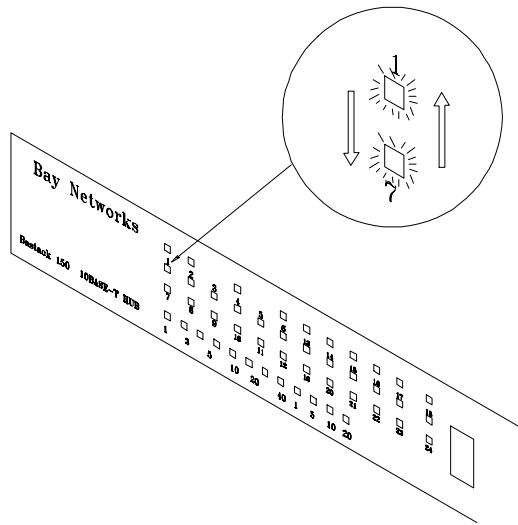

**Figure 10. Link Light Locations 1 and 7.**

- Disconnect the power cable from the power source and then from the hub.

## Reassembling the BayStack 150/152 Ethernet Hub

To reassemble the BayStack 150/152 Ethernet hub:

1. **Replace three male head pins on the upper board ([Figure 11](#)), matching them with their female counterparts in the bottom interior of the hub. Firmly, but gently, secure the head pins.**

Verify that the head pin on the lower left side of the board has been secured, as in step 5c.

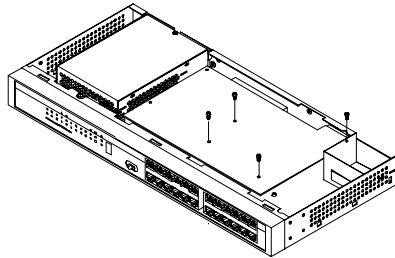

Figure 11. Replacing the Upper Board

2. **Reattach the top panel by aligning the comm port gap of the top panel with the comm port gap in the bottom of the hub ([Figure 12](#)).**

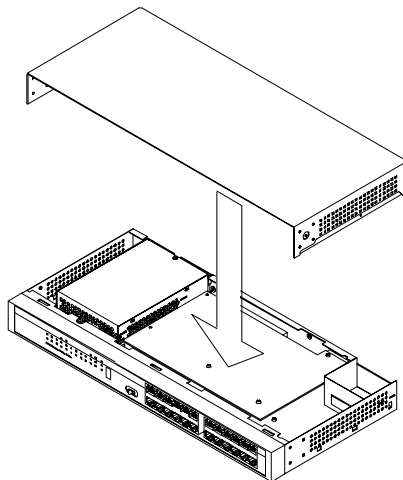

Figure 12. Replacing the Top Panel

3. Using the hex-head screwdriver, replace and secure the two hex-head screws in the comm port ([Figure 2](#)).
4. Using the Phillips-head screwdriver, securely replace the two flat-head screws each on the left, right, and rear of the hub ([Figure 2](#)).

Make sure that the new boot firmware is installed correctly before you reconnect the hub.



**Caution:** Applying power to incorrectly installed boot firmware can cause damage to the hub.

---

## Bay Networks Technical Publications

You can now print Bay Networks technical manuals and release notes free, directly from the Internet. Go to [support.baynetworks.com/library/tpubs/](http://support.baynetworks.com/library/tpubs/). Find the Bay Networks product for which you need documentation. Then locate the specific category and model or version for your hardware or software product. Using Adobe Acrobat Reader, you can open the manuals and release notes, search for the sections you need, and print them on most standard printers. You can download Acrobat Reader free from the Adobe Systems Web site, [www.adobe.com](http://www.adobe.com).

You can purchase Bay Networks documentation sets, CDs, and selected technical publications through the Bay Networks Collateral Catalog. The catalog is located on the World Wide Web at [support.baynetworks.com/catalog.html](http://support.baynetworks.com/catalog.html) and is divided into sections arranged alphabetically:

- The “CD ROMs” section lists available CDs.
- The “Guides/Books” section lists books on technical topics.
- The “Technical Manuals” section lists available printed documentation sets.

Make a note of the part numbers and prices of the items that you want to order. Use the “Marketing Collateral Catalog description” link to place an order and to print the order form.

## How to Get Help

For product assistance, support contracts, or information about educational services, go to the following URL:

*<http://www.baynetworks.com/corporate/contacts/>*

Or telephone the Bay Networks Technical Solutions Center at:

800-2LANWAN

